

SDC Security Door Controls

3580 Willow Lane, Westlake Village, CA 91361-4921 • (805) 494-0622 • Fax: (805) 494-8861
www.sdcsecurity.com • E-mail: service@sdsecurity.com

INSTALLATION/PROGRAMMING INSTRUCTIONS 928 ENTRYCHECK®

INTRODUCTION

The 928 EntryCheck™ is a digital keyless entry system designed for access control applications. The keypad is housed in a rugged, plastic enclosure and is designed to be mounted in a standard single-gang electrical box. The die-cast keys have bright, easy-to-read yellow graphics.

Up to 480 entry codes, from 1 to 6 digits in length, can be programmed. They can activate either, or both of the relay outputs. The “anti-passback” feature prevents using the same code again before the programmed time elapses.

All system indicators are long-lasting, solid state LEDs. Two indicators show the status of the entry system. The left indicator lights red to indicate power, then turns green when access is granted. The right indicator lights yellow when the keypad is in “lockout” condition (from too many incorrect code entries). An internal sounder beeps when each key is pressed. An internal jumper sets the sounder volume high or low

The **SENSE** input can be used two ways. If programmed for “door sense” the input is wired to a normally closed switch on the door to detect when the door is opened or closed. Forced entry or door ajar situations can then be detected. Using door sense, the “Auto-relock” feature will prevent “tailgating” by turning off the Main Relay output immediately when the door is closed after access has been granted. If the **SENSE** input is programmed for “inhibit”, the input can be wired to a “service” switch or automatic timer that will disable the Main Relay when required.

The **REQUEST-TO-EXIT** input can be wired to a pushbutton to provide codeless activation of Main Relay, Auxiliary Relay, Output #3 or Output #4 (programmable).

The **ALARM SHUNT** output activates when access is granted. This output can be wired to shunt alarm contacts on the access door/gate to prevent triggering of an alarm when authorized access occurs.

The 928 EntryCheck™ is powered from a 12-24V AC or DC source. Power can be obtained from the access device or a separate power supply. The EEPROM memory retains all entry codes and programming, even without power. An internal jumper is provided to reset the master code. The Main Relay has a 5 Amp capacity. The Auxiliary Relay has a 1 Amp capacity. Two solid state outputs, capable of switching 100 mA to common, are programmable to signal forced entry, door ajar, lockout, alarm circuit shunting, request-to-exit, and keypad active conditions.



Features

- Keypad programmable
- 480 user codes
- 1 to 6 digit user codes
- 4 independent outputs
- 4 independent timers
- 2 Form C relay contacts
- 2 solid state open collector outputs
- Program entry codes to activate one or two relays
- Disable input
- Door sense input
- Request-to-exit/enter input
- Keypad tamper lockout
- Timed anti-passback
- Anti-tailgate
- Two LED status indicators
- Tactile key feel
- Audible code entry verification
- 12 or 24V, AC or DC operation

COMPONENT LOCATIONS

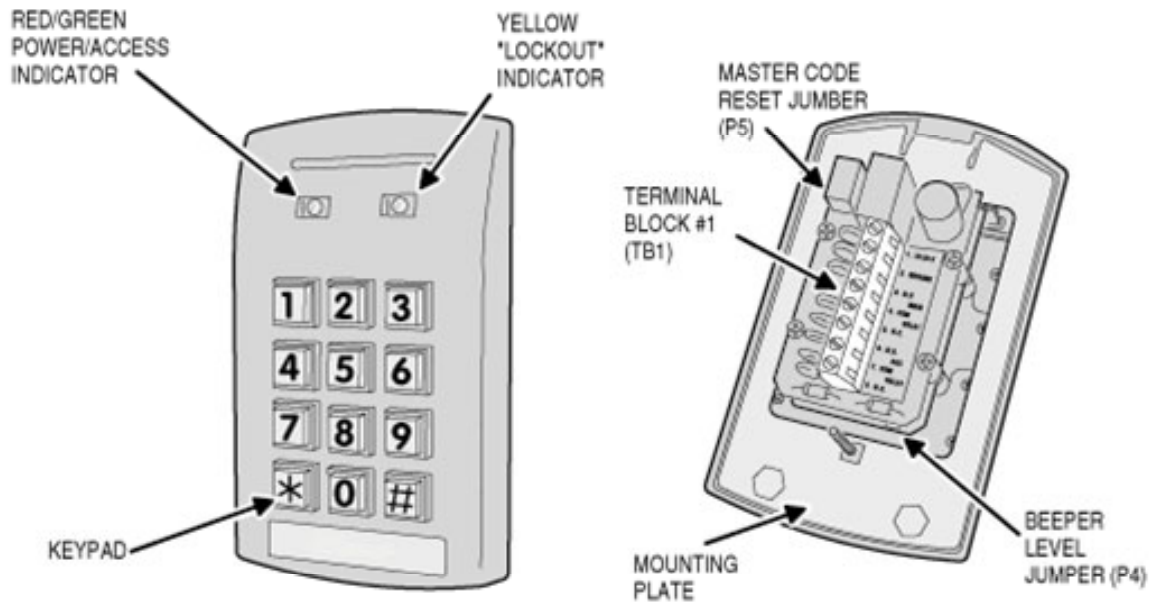

Fig.1 Component Locations

WIRING DIAGRAM

TYPICAL DOOR INSTALLATION WIRING

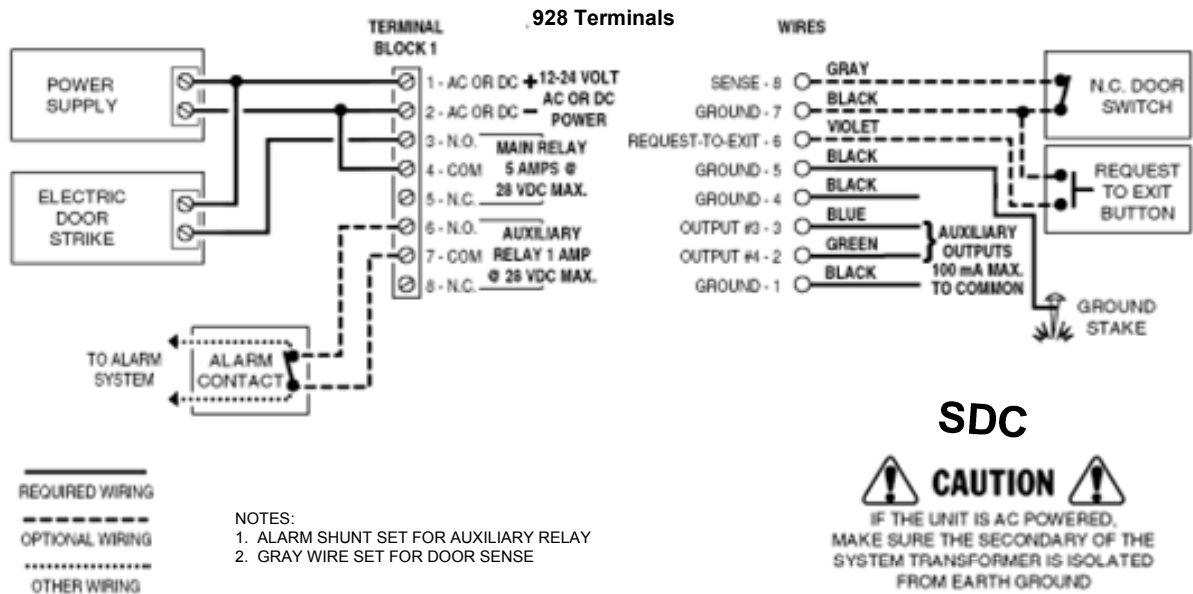

Fig. 2 Wiring Diagram

INSTALLATION

Before installing the keypad, the unit must be partially disassembled to access the mounting plate.

Opening the Keypad

The keypad assembly is secured with two screws that are hidden behind the keypad's nameplate. Refer to Fig. 3 for disassembly details.

- Use a small flat blade screwdriver to pry off the keypad's nameplate
- Use a philips head screwdriver to remove the two screws.
- Separate the mounting plate from the keypad assembly

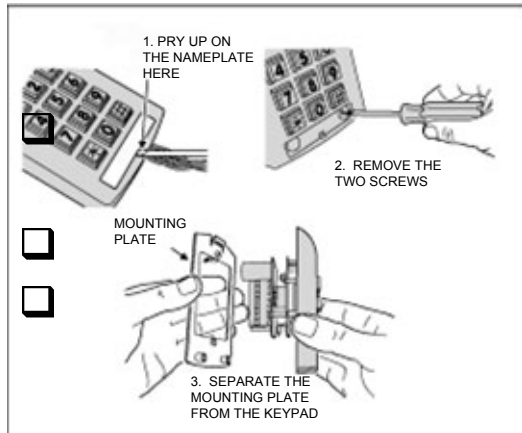

Fig. 3 Opening the Keypad

Final Keypad Installation

After wiring the keypad (see next page), complete the installation by securing the keypad to the mounting plate.

- If a lower beeper sound level is required, before installing the keypad, remove Jumper at P4 (place the jumper block on one pin to save the jumper).
- Hook the keypad assembly onto the mounting plate tab (see fig. 5).
- Secure with two philips screws.
- Snap nameplate into position over screws.

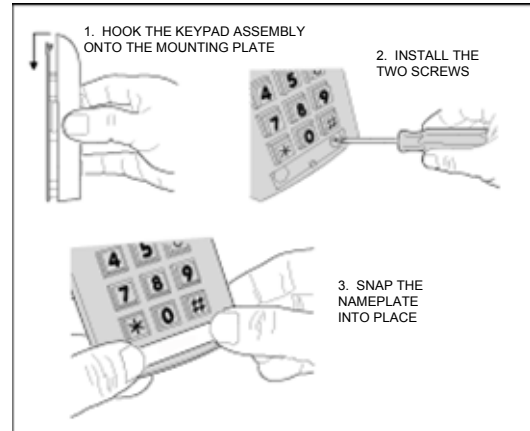

Fig. 5 Connecting the Keypad to the Mounting Plate

Install the Electrical Box and Mounting Plate

The keypad is designed to fit into a standard single-gang electrical box. Select a location near the controlled door and choose a convenient height for the keypad. Be sure there is good wiring accessibility for the unit's power and the output to the door strike or access device.

- Install the electrical box in the wall.
- Screw the mounting plate onto the electrical box (see Fig. 4)

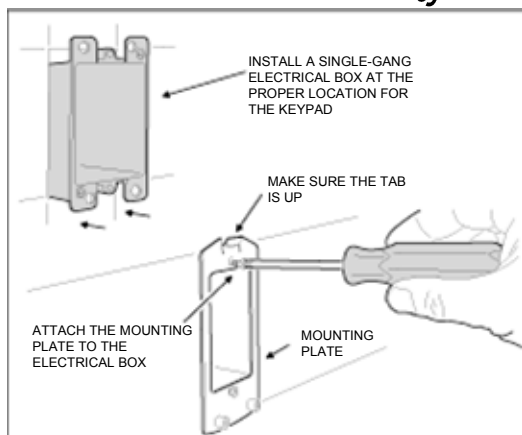

Fig. 4 Installing the Mounting Plate

KEYPAD WIRING

See Fig. 6 for an example of a basic door installation. The keypad is mounted adjacent to the door. An electric door strike is mounted in the door jamb to release the door lock. A magnetic switch is mounted on top of the door jamb for detecting when the door is open.

Use the following steps to wire the keypad. Refer to the wiring diagram shown in Fig. 8 to assist in the wiring.

Note: Up to 500 feet of 18 AWG wire can be run for power, use larger wire for longer runs. Use 22 AWG or larger (depending on load) for other connections.

OUTPUT

Install a low voltage electric door strike for unlocking the door.

Route two wires between the door strike and the keypad box. Connect one of the door strike wires to the keypad's MAIN RELAY N.O. terminal (TB1 #3). Connect the other door strike wire to the keypad's AC/DC+ terminal (TB #1). Connect a wire between the keypad's AC/DC- terminal (TB #2) and the MAIN RELAY COM terminal (TB #4).

POWER

Choose a location for the power supply or transformer. Route two wires between the door strike and the keypad box. Connect the power supply's output terminals to the keypad's AC/DC input terminals (TB #1 & #2). Observe wiring polarity if using DC.

Caution: If the unit is AC powered, make sure the secondary of the system transformer is isolated from earth ground.

EARTH GROUND

To avoid damage to the unit from static discharges, connect the EARTH GROUND black wires E1, 4, 5 or 8 to a good earth grounding point. Suggested wiring size is 18 AWG for earth ground.

SENSE INPUT

Note: SENSE terminal (gray wire) can be programmed for either a door sense or inhibit input. Both features cannot be used at the same time.

To use the door sense feature to detect forced entry or door ajar conditions, install a normally closed door switch on the door and route two wires from the switch to the keypad box. Connect the door switch to the keypad's SENSE terminal (gray wire E8) and COM terminal (any black wire). If an inhibit switch or timer is going to be used for temporarily disabling the keypad, route two wires from the switch or timer to the keypad box. Connect the inhibit switch/timer normally open terminals to the keypad's SENSE (gray wire E8) and COM (black wires) terminal.

REQUEST-TO-EXIT INPUT (wiring shown on page 2, fig. 2)

If a request-to-exit pushbutton is going to be used, route two wires from the keypad box to a normally open pushbutton mounted on the secure side of the door. Connect the wires to the pushbutton and to the keypad's EXIT (violet wire E6) and COM (black wires) terminals.

Solid State Outputs

The two solid state outputs (Outputs #3 & #4) can be programmed to activate during various conditions. These outputs can be used to activate indicators or sounders. See fig. 9 for wiring examples using the solid state outputs.

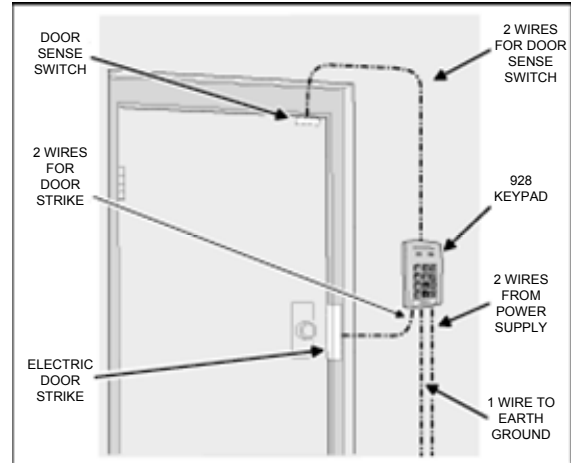

Fig. 6 Basic Door Installation

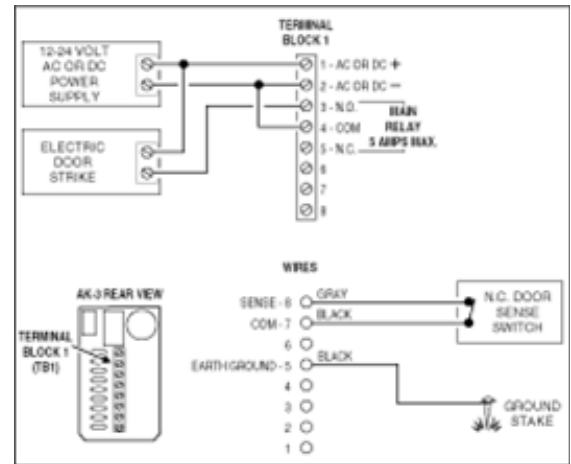

Fig. 7 Basic Door Installation Wiring

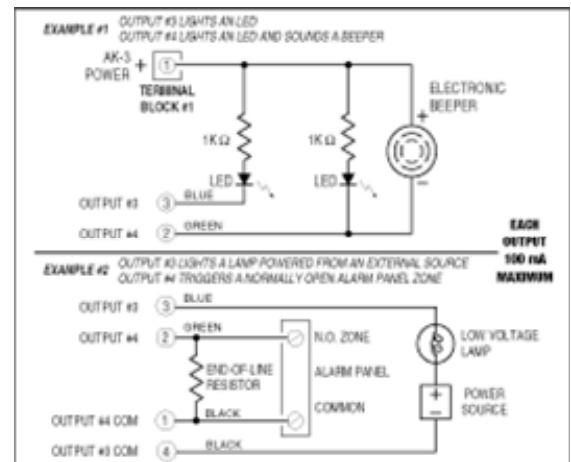

Fig. 8 Using Solid State Outputs

FACTORY DEFAULTS

Master Programming Code.....	123456
Entry Code Length.....	4 digits
Request-to-exit Output Relay.....	Main Relay
Alarm Shunt Output.....	Disabled
Forced Entry Output.....	Output #3
Door Ajar Output.....	Output #4
Main Relay On Time.....	2 Seconds
Auxiliary Relay On Time.....	2 Seconds
Solid State Output #3 On Time.....	2 Seconds
Solid State Output #4 On Time.....	2 Seconds
Door Sense/Inhibit Input.....	Door Sense
Keypad Lockout Output.....	Disabled
Keypad Active Output.....	Disabled
Beeper Sounds When Key Pressed.....	Yes
Beeper Sounds During Relay #1.....	No
Beeper Sounds During Relay #2.....	No
Beeper Sounds During Output #3.....	No
Beeper Sounds During Output #4.....	No
Keypad Lockout Count.....	3 Tries Before Lockout
Anti-Passback Time.....	No Anti-Passback
Auto-Relock.....	On

BASIC PROGRAMMING

When the 928 EntryCheck™ is in Programming Mode, both indicators will turn off until programming begins. After a programming option number is entered, the yellow indicator will blink. This shows that the 928 is ready to accept the new programming data. After the new data entry is complete, the yellow indicator will flash while the data is being stored. The green indicator will light if the data is accepted. The red indicator will light if any programming data is entered incorrectly, and the command will have to be fully re-entered.

Entering Programming Mode

The 6-digit Master Programming Code (default = 123456) is used to enter Programming Mode.

Press: # 9 # Master Code

Master Code = the current 6-digit Master Programming Code

Exiting Programming Mode

Press: ** #

The red indicator will light after exiting Programming Mode

Note: *The 928 will automatically exit Programming Mode after two minutes of inactivity*

Re-entering a Command After a Mistake

If the red indicator lights, signaling an incorrect entry, or an incorrect key is pressed during programming, to clear the keypad and re-enter the command:

Press: * 9 #

Re-entering a Command After a Mistake

If the red indicator lights, signaling an incorrect entry, or an incorrect key is pressed during programming, to clear the keypad and re-enter the command:

Press: * 9 #

Setting Entry Code Length

Default: 4 digits

Press: 0 3 # Length #

Length = 1-6 for entry code length

Note: *If the Entry Code Length is going to be changed from the factory default of 4 digits, make this change first before programming any entry codes.*

Adding a New Entry Code

Press: 0 1 # Code # Code # Relay #

Code=*The new entry code: 1-999999, depending on code length*

Relay=*Relay output entry code will activate:*

1=Main Relay 2=Auxiliary Relay 3=Both Relays

The yellow indicator will flash quickly while the AK-3 searches its memory for available space and duplicate entries. The green indicator will light when the new code is stored.

If the new entry code chosen is already being used for another entry code, the red indicator will light. A new unique code needs to be entered.

Note: *Leading zeros (zeros before the code number, i.e.0001) do not need to be entered when programming a new code. The 928 will internally add any zeros to fill digits determined by the entry code length setting. Leading zeros will have to be entered by the user when entering their code to gain access.*

Erasing a Single Entry Code

Press: 0 2 # Code # Code #

Code=*The entry code to delete*

The yellow indicator will flash quickly while the 928 searches its memory for the code to erase. The green indicator will light when the code is erased.

Erasing All Entry Codes

WARNING: PERFORMING THIS COMMAND WILL REMOVE ALL ENTRY CODES FROM THE MEMORY

Press: 9 7 # 0 0 0 0 0 # 0 0 0 0 0 #

NOTE: The green indicator will light while the memory is being erased. This may take up to 15 seconds.

Changing the 6-Digit Master Programming Code

Press: 9 8 # Master Code # Master Code #

Master Code=*The new 6-digit Master Programming Code*

New master code: _____

PROGRAMMING OPTIONS

There are several 928 EntryCheck™ programming options. For most installations, the factory set default options are sufficient. The keypad must be in Programming Mode to make these changes.

Programming the 928 To Hold the Output

SDC's EntryCheck™ products have a programmable "Toggle Mode" available for each relay and solid-state output. When an output is programmed for Toggle Mode, the output alternates from OFF to ON or from ON to OFF each time it is activated.

The rules for a toggle output are:

If the output is OFF, it will turn ON and stay on until the next activation.

If the output is ON, it will turn OFF and stay off until the next activation.

Typical Programming

With the unit in Program Mode, set the Auxiliary Relay (Relay #2) output to Toggle Mode using the following keystrokes.

Press: 2 2 # 9 9 #

22=Programming Step; 99=Toggle Mode

Program all normal entry codes to use the Main Relay (Relay #1), and only Relay #1 as the output relay. Program the code(s) that you want to use to hold the output for an indefinite period to the Auxiliary Relay (Relay #2). See the following example that sets entry codes 1234 for normal and 5678 for toggle operation.

Press: 0 1 # 1 2 3 4 # 1 2 3 4 # 1 #

01=Programming Step; 1234=Entry Code; 1=Main Relay

Press: 0 1 # 5 6 7 8 # 5 6 7 8 # 2 #

01=Programming Step; 5678=Entry Code; 2=Auxiliary Relay

Typical Toggle Mode Wiring

For devices triggered by a normally open circuit, wire the contacts of the Main and Auxiliary Relays in parallel (see the Figure below). Either relay will be able to trigger the access device. Entry codes programmed for the Auxiliary Relay will be able to hold the output on.

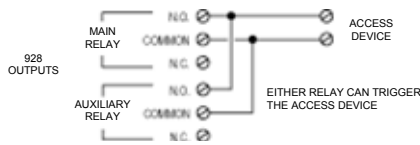

Select Door Sense or Inhibit Input Default: Door Sense

The input (gray wire) can be programmed for DOOR SENSE or INHIBIT.

Press: 1 0 # Input #

Input=0 for Door Sense; =1 for Inhibit

When programmed for DOOR SENSE, if an open condition on the input occurs before access is granted (with an entry code or with the request-to-enter input) a FORCED ENTRY output will occur. If an open condition remains 60 seconds after a relay activation for access, a DOOR AJAR output will occur.

When programmed for INHIBIT, a closed condition on the input will prevent Relay #1 from activating when access is requested with an entry code. This mode is typically used with an external timer to disable the access device at certain times.

Select Forced Entry Output Default: Output #3

Sets which output activates if the DOOR SENSE input opens before access is granted. This output is not timed.

Press: 1 1 # Output #

Output=Output to Activate(0-4)

1=Main Relay; 2=Auxiliary Relay; 3=Output #3; 4=Output #4; 0=No Output

Select Door Ajar Output Default: Output #4

Sets which output activates if the DOOR SENSE input stays open 60 seconds after access is granted. This output is not timed.

Press: 1 2 # Output #

Output=Output to Activate (0-4)

1=Main Relay; 2=Auxiliary Relay; 3=Output #3; 4=Output #4; 0=No Output

Setting Entry Code Length Default: 4 digits

Press: 0 3 # Length #

Length = 1-6 for entry code length

Note: If the Entry Code Length is going to be changed from the factory default of 4 digits, make this change first before programming any entry codes.

Select Keypad Lockout Output Default: No Output

Sets which output activates when the keypad is "locked out" after too many incorrect entry code attempts. The lockout time is 60 seconds.

Press: 1 3 # Output #

Output=Output to Activate (0-4)

1=Main Relay; 2 = Auxiliary Relay; 3=Output #3; 4=Output #4; 0=No Output

Select Keypad Active Output Default: No Output

Sets which output activates when any keys are pressed. This output is timed. If toggle mode is selected for the output, the timer value defaults to 2 seconds.

Press: 1 4 # Output #

Output=Output to Activate(0-4)

1=Main Relay; 2=Auxiliary Relay; 3=Output #3; 4=Output #4; 0=No Output

Select Alarm Shunt Output Default: No Output

Sets which output activates during the time access is granted. (Use this output of shunt alarm contacts attached to the access door.) This output may be timed or toggled.

Press: 1 5 # Output #

Output=Output to Activate(0-4)

1=Main Relay; 2=Auxiliary Relay; 3=Output #3; 4=Output #4; 0=No Output

Select Request-to-Exit Output Default: Main Relay

Sets which output activates when the Request-to-Exit input is grounded. This output may be timed or toggled.

Press: 1 6 # Output #

Output=Output to Activate(0-4)

1=Main Relay; 2=Auxiliary Relay; 3=Output #3; 4=Output #4; 0=No Output

Main Relay On-time Default: 2 Seconds

Sets the length of time the Main Relay activates when triggered.

Press: 2 1 # Seconds #

Seconds=Output time in seconds (0-60), 99=Toggle Mode

Auxiliary Relay On-time Default: 2 Seconds

Sets the length of time the Auxiliary Relay activates when triggered.

Press: 2 2 # Seconds #

Seconds=Output time in seconds (0-60), 99=Toggle Mode

Solid-state Output #3 On-time Default: 2 Seconds

Sets the length of time Output #3 activates when triggered.

Press: 2 3 # Seconds #

Seconds=Output time in seconds (0-60), 99=Toggle Mode

Solid-state Output #4 On-time Default: 2 Seconds

Sets the length of time Output #4 activates when triggered.

Press: 2 4 # Seconds #

Seconds=Output time in seconds (0-60), 99=Toggle Mode

Beep Sounds on Keystrokes Default: 2 Seconds

Selects whether or not the keypad beeps as each key is pressed.

Press: 4 0 # Sound #

Sound=1 for Yes, =0 for No

Beep Sounds During Main Relay Default: 2 Seconds

Selects whether or not the keypad beeps during Main Relay activation.

Press: 4 1 # Sound #

Sound=1 for Yes, =0 for No

Beep Sounds During Auxiliary Relay **Default: No**

Selects whether or not the keypad beeps during Auxiliary Relay activation.

Press: 4 2 # Sound #
Sound=1 for Yes, =0 for No

Beep Sounds During Output #3 **Default: No**

Selects whether or not the keypad beeps during Output #3 activation.

Press: 4 3 # Sound #
Sound=1 for Yes, =0 for No

Beep Sounds During Output #4 **Default: No**

Selects whether or not the keypad beeps during Output #4 activation.

Press: 4 4 # Sound #
Sound=1 for Yes, =0 for No

Keypad Lockout Count **Default: 3 Tries**

Sets the number of incorrect entry code attempts allowed before the keypad "locks out".

Press: 5 0 # Attempts #
Attempts=Number of attempts before lockout (2-7)

Anti-passback Time **Default: No Anti-passback**

Sets the length of time an entry code will not function after it is used.

Press: 5 1 # Minutes #
Minutes=Time in minutes (1-4), 0=No Anti-passback

RESETTING KEYPAD

Master Reset

CAUTION: Performing a master reset will clear the entire memory of the 928 and return all programmable options to the factory default values. ALL ENTRY CODES WILL BE ERASED.

- STEP 1** Disconnect power from the keypad.
- STEP 2** Press and hold down the * and # keys.
- STEP 3** Apply power to the keypad, continue holding the keys down until the red indicator starts flashing
- STEP 4** Release the keys. The red and yellow indicators will remain lit until the process is complete, then the yellow indicator will go out.

Resetting the Master Code

- STEP 1** Open the 928 case.
- STEP 2** Locate jumper at P2. This jumper is used to reset the master code.
- STEP 3** With power applied to the keypad, remove the jumper at P2. The keypad will begin to beep, signaling that the code has been reset.
- STEP 4** Replace jumper on P2
THE MASTER PROGRAMMING CODE IS NOW 123456.

928 ENTRYCHECK™ OPERATION

Keypad users request access by entering their code.

Users of the 928 have up to 40 seconds to key in their entry code.

Up to eight seconds are allowed between each keystroke. All digits of the entry code must be entered. Example: if the code is 0042, the user must enter "0 0 4 2".

If the wrong key is pressed, pressing the * key will reset the keypad. The correct code can be re-entered.

After a correct code is entered, the red indicator will turn green and the programmed relay will activate for the programmed time.

If the number of incorrect codes entered exceeds the keypad lockout count, the yellow indicator will light, indicating that the keypad is locked out. The lockout will remain for one minute.

After a valid code has been entered, it will be unusable until the anti-passback time expires.

SPECIFICATIONS

Mechanical

Dimensions: 3.00" W x 5.00" H x 3.00" D

Electrical

Voltage: 12-24 Volts AC or DC

Current: 30 mA typical, 150 mA maximum

Outputs: Main Relay:

Form "C" 5 Amps @ 28 Volts maximum

Auxiliary Relay:

Form "C" 1 Amp @ 28 Volts maximum

Solid state outputs (Outputs #3 & #4)

Short-to-common 100 mA @ 24 VDC maximum

Environmental

Temperature: -22°F to 149°F (-30°C to 65°C)

Humidity: 5% to 95% non-condensing

SDC LIMITED WARRANTY

This SDC product is warranted against defects in material and workmanship for twelve (12) months. The Warranty Expiration Date is labeled on the product. **This warranty extends only to wholesale customers** who buy direct from SDC or through SDC's normal distribution channels. **SDC does not warrant this product to consumers.** Consumers should inquire from their selling dealer as to the nature of the dealer's warranty, if any. **There are no obligations or liabilities on the part of SDC Corporation for consequential damages arising out of or in connection with use or performance of this product or other indirect damages with respect to loss of property, revenue, or profit, or cost of removal, installation, or reinstallation.** All implied warranties, including implied warranties for merchantability and implied warranties for fitness, are valid only until Warranty Expiration Date as labeled on the product. **SDC Warranty is in lieu of other warranties express or implied.**

All products returned for warranty service require a Return Goods Authorization Number (RGA#). Contact SDC at (805) 494-0622.

FCC NOTICE

Changes or modifications not expressly described in this manual or approved by the manufacturer could void the user's authority to operate the equipment. This equipment has been tested and found to comply with the limits for a Class B digital device, pursuant to Part 15 of the FCC Rules. These limits are designed to provide reasonable protection against harmful interference in a residential installation. This equipment generates, uses and can radiate radio frequency energy and, if not installed and used in accordance with the instructions, may cause harmful interference to radio communications. However, there is no guarantee that interference will not occur in a particular installation. If this equipment does cause harmful interference to radio or television reception, which can be determined by turning the equipment off and on, the user is encouraged to try to correct the interference by one or more of the following measures:

Reorient or relocate the receiving antenna.

Increase the separation between the equipment and receiver.

Connect the equipment into an outlet on a circuit different from that to which the receiver is connected.

Consult the dealer or an experienced radio/TV technician for help.